

# DATA SHEET

## **TDA9860**

Universal HiFi audio processor for  
TV

Preliminary specification  
File under Integrated Circuits, IC02

July 1994

# Universal HiFi audio processor for TV

# TDA9860

## FEATURES

- Multi-source selector switches six AF inputs (three stereo sources or six mono sources)
- Each of the input signals can be switched to each of the outputs (crossbar switch)
- Outputs for loudspeaker channel, headphone channel and peri-TV connector (SCART)
- Switchable spatial stereo and pseudo stereo effects
- Audio surround decoder can be added externally
- Two general purpose logic output ports
- I<sup>2</sup>C-bus control of all functions.



## GENERAL DESCRIPTION

The TDA9860 provides control facilities for the main, the headphone and the SCART channel of a TV set. Due to extended switching possibilities, signals from 3 stereo sources can be handled.

## QUICK REFERENCE DATA

SYMBOL	PARAMETER	MIN.	TYP.	MAX.	UNIT
V <sub>P</sub>	positive supply voltage (pin 6)	7.2	8.0	8.8	V
I <sub>P</sub>	supply current	–	25	–	mA
V <sub>i</sub>	input signal levels for 0 dB gain (RMS value)	2	–	–	V
V <sub>o</sub>	output signal levels for 0 dB gain (RMS value)	2	–	–	V
G <sub>v</sub>	gain in main channel				
	volume control (1 dB steps, balance included)	–63	–	+15	dB
	bass control (1.5 dB steps)	–12	–	+15	dB
	treble control (3 dB steps)	–12	–	+12	dB
	gain in headphone channel				
	volume control (2 dB steps)	–70	–	0	dB
	gain for muting in all channels	–80	–	–	dB
THD	total harmonic distortion	–	0.1	–	%
S/N	signal-to-noise ratio	–	85	–	dB
T <sub>amb</sub>	operating ambient temperature	0	–	+70	°C

## ORDERING INFORMATION

EXTENDED TYPE NUMBER	PACKAGE			
	PINS	PIN POSITION	MATERIAL	CODE
TDA9860	32	SDIL	plastic	SOT232 <sup>(1)</sup>

### Note

1. SOT232-1; 1996 November 21.

Universal HiFi audio processor for TV

TDA9860

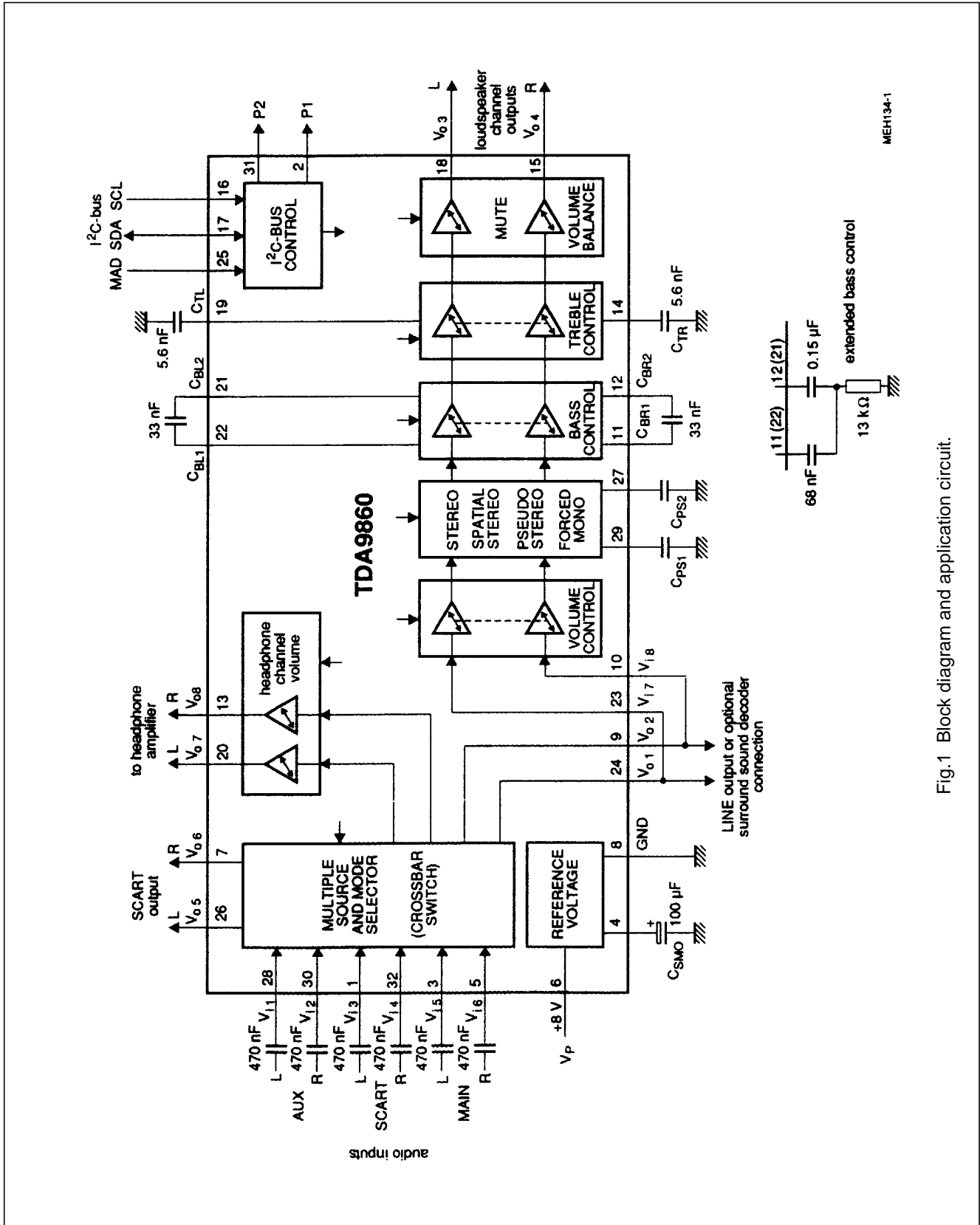

Fig.1 Block diagram and application circuit.

MEH134-1

Universal HiFi audio processor for TV

TDA9860

PINNING

SYMBOL	PIN	DESCRIPTION
V <sub>i3</sub>	1	SCART input signal LEFT
P1	2	port 1 output
V <sub>i5</sub>	3	MAIN input signal LEFT
C <sub>SMO</sub>	4	smoothing capacitor of reference voltage
V <sub>i6</sub>	5	MAIN input signal RIGHT
V <sub>P</sub>	6	positive supply voltage
V <sub>o6</sub>	7	SCART output signal RIGHT
GND	8	ground
V <sub>o2</sub>	9	MAIN output signal RIGHT
V <sub>i8</sub>	10	input signal RIGHT to loudspeaker channel
C <sub>BR1</sub>	11	bass capacitor RIGHT 1
C <sub>BR2</sub>	12	bass capacitor RIGHT 2
V <sub>o8</sub>	13	headphone output signal RIGHT
C <sub>TR</sub>	14	treble capacitor RIGHT
V <sub>o4</sub>	15	loudspeaker channel output signal RIGHT
SCL	16	I <sup>2</sup> C-bus clock line
SDA	17	I <sup>2</sup> C-bus data line
V <sub>o3</sub>	18	loudspeaker channel output signal LEFT
C <sub>TL</sub>	19	treble capacitor LEFT
V <sub>o7</sub>	20	headphone output signal LEFT
C <sub>BL2</sub>	21	bass capacitor LEFT 2
C <sub>BL1</sub>	22	bass capacitor LEFT 1
V <sub>i7</sub>	23	input signal LEFT to loudspeaker channel
V <sub>o1</sub>	24	MAIN output signal LEFT
MAD	25	module address select input
V <sub>o5</sub>	26	SCART output signal LEFT
C <sub>PS2</sub>	27	pseudo stereo capacitor 2
V <sub>i1</sub>	28	AUX input signal LEFT
C <sub>PS1</sub>	29	pseudo stereo capacitor 1
V <sub>i2</sub>	30	AUX input signal RIGHT
P2	31	port 2 output
V <sub>i4</sub>	32	SCART input signal RIGHT

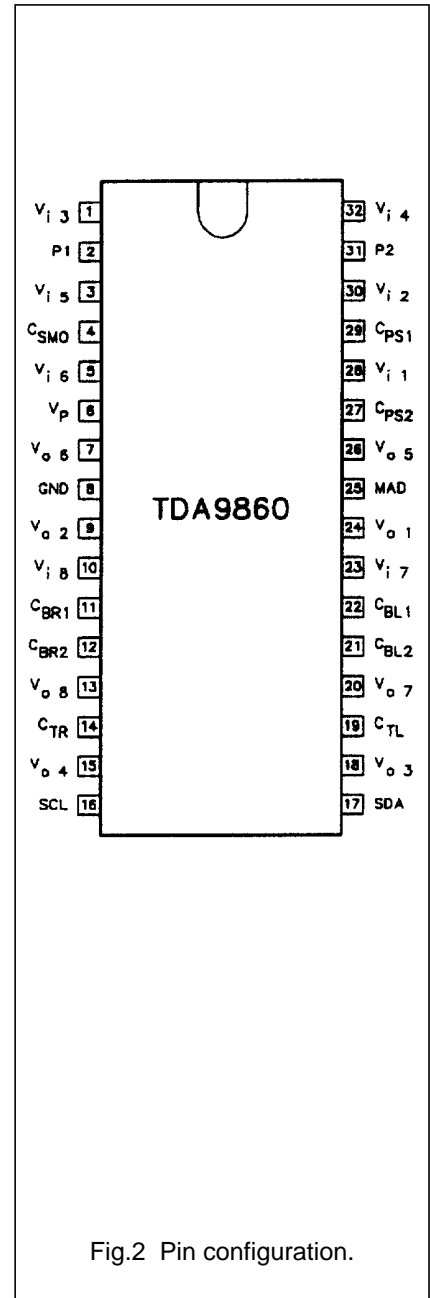

Fig.2 Pin configuration.

# Universal HiFi audio processor for TV

# TDA9860

## FUNCTIONAL DESCRIPTION

The TDA9860 consists of the following functions:

- source select switching block
- loudspeaker channel with effect controls
- headphone channel
- two port outputs for general purpose
- I<sup>2</sup>C-bus control

### Source select switching block

The TDA9860 selects and switches the input signals from three stereo or six mono sources as there are MAIN, AUX and SCART (Fig.1) to one of the outputs SCART, loudspeaker and headphone (crossbar-switching Table 3). Due to the fact, that the main channel (LINE outputs) is looped outside the circuit (from pins 9 and 24 to pins 10 and 23), signals can be used as LINE output or to insert a 'surround sound decoder'.

### Loudspeaker channel

Volume control is divided into the parts volume 1 and volume 2 / balance. The first part (55 dB) controls left and right channels simultaneously; the second part (23 dB)

controls volume and balance of left and right channels independently. Treble control provides a control range from -12 to +12 dB and bass control from -12 to +15 dB. Extended bass control can be provided by an external T-network (Fig.1) from -15 to +19 dB (2 dB steps).

### Effect controls

'Linear stereo', 'stereo with spatial effect (30% or 52% anti-phase crosstalk)' and 'forced mono with or without pseudo-stereo effect' are controlled by three bits. A muting of 85 dB is provided.

### Headphone channel

The headphone channel is only equipped with volume / balance control. A muting of 85 dB is provided.

### I<sup>2</sup>C-bus control

All settings of control are stored in subaddress registers. Data transmission is simplified by auto-incrementing the subaddresses. The on-chip power on reset sets the mute bit to active, so all 3 stereo outputs are muted. The muting can be switched off by writing a '0' (non-muted) into the mute control bits.

## LIMITING VALUES

In accordance with the Absolute Maximum Rating System (IEC 134).

SYMBOL	PARAMETER	MIN.	MAX.	UNIT
V <sub>P</sub>	supply voltage (pin 6)	0	10	V
V <sub>n</sub>	voltage on all pins, ground excluded	0	V <sub>P</sub>	V
I <sub>o</sub>	output current			
	at pins 15, 18, 13, 20, 7 and 26	-	2.5	mA
	at pins 2 and 31	-	1.5	mA
P <sub>tot</sub>	total power dissipation	-	850	mW
T <sub>stg</sub>	storage temperature	-25	+150	°C
T <sub>amb</sub>	operating ambient temperature	0	+70	°C
V <sub>ESD</sub>	electrostatic handling for all pins (note 1)	-	±300	V
	electrostatic handling for all pins (note 2)	-	±2000	V

### Notes to the Limiting Values

1. Equivalent to discharging a 200 pF capacitor through a 0 Ω series resistor.
2. Equivalent to discharging a 100 pF capacitor through a 1.5 kΩ series resistor.

## THERMAL RESISTANCE

SYMBOL	PARAMETER	THERMAL RESISTANCE
R <sub>th j-a</sub>	from junction to ambient in free air	60 K/W

## Universal HiFi audio processor for TV

TDA9860

**CHARACTERISTICS**

$V_P = 8\text{ V}$ ;  $T_{amb} = +25\text{ °C}$ ; treble and bass in linear positions; balance in mid position; spatial function, pseudo-stereo function and forced-mono function in off position and measurements taken in Fig.1 unless otherwise specified.

SYMBOL	PARAMETER	CONDITIONS	MIN.	TYP.	MAX.	UNIT
$V_P$	supply voltage (pin 6)		7.2	8.0	8.8	V
$I_P$	supply current (pin 6)		–	25	–	mA
$V_{ref}$	internal reference voltage		–	$V_P/2$	–	V
$V_4$	voltage (pin 4)		–	$V_P - 0.1$	–	V
<b>DC voltage on pins</b>						
$V_I$	DC input voltage (pins 1, 3, 5, 10, 23, 28, 30 and 32)		–	$V_P/2$	–	V
$V_O$	DC output voltage (pins 7, 9, 13, 15, 18, 20, 24 and 26)		–	$V_P/2$	–	V
$V_C$	DC voltage on capacitors (pins 11, 12, 14, 19, 21, 22, 27 and 29)		–	$V_P/2$	–	V
<b>Audio select switch. Line, SCART and headphone outputs (controlled via I<sup>2</sup>C-bus, Table 3)</b>						
$V_i$	maximum AF input signal on pins 1, 3, 5, 28, 30, 32 (RMS value)	THD $\leq$ 0.5% on output pins	2	–	–	V
$R_i$	input resistance (pins 1, 3, 5, 28, 30, 32)		20	30	40	k $\Omega$
f	frequency response for all AF outputs	–0.5 dB	20	–	20000	Hz
$V_o$	maximum AF output signal on pins 7, 9, 24, 26 (RMS value)	THD $\leq$ 0.5%	2	–	–	V
$R_L$	allowed external load resistance					
	on output (pins 9 and 24)		10	–	–	k $\Omega$
	on output (pins 7 and 26)		5	–	–	k $\Omega$
$G_v$	gain for all signal arms		–	0	–	dB
$\alpha_{cr}$	switch crosstalk on outputs between AF inputs at f = 10 kHz	unused inputs connected to ground	–	90	–	dB
<b>LOUDSPEAKER CHANNEL (controlled via I<sup>2</sup>C-bus, Table 3)</b>						
<b>Volume control 1 (LEFT and RIGHT simultaneously) f = 1 kHz, 55 steps</b>						
$V_i$	maximum input signal (RMS value; pins 10 and 23)	$G_v = 0$ ; THD $\leq$ 0.5% on output pins 15 and 18	2	–	–	V
$R_i$	input resistance (pins 10 and 23)		7.5	10	–	k $\Omega$
$G_v$	nominal volume control		–40	–	+15	dB
	minimum volume control		–38	–	+14	dB
$\Delta G_v$	step width	$G_v = -32$ to +15 dB	0.5	1.0	1.5	dB
		$G_v = -40$ to –33 dB	0.25	1.0	1.75	dB
	gain set error	$G_v = -32$ to +15 dB	–	–	1	dB
		$G_v = -40$ to –33 dB	–	–	2	dB

## Universal HiFi audio processor for TV

TDA9860

SYMBOL	PARAMETER	CONDITIONS	MIN.	TYP.	MAX.	UNIT
<b>Volume 2 / balance control</b>		f = 1 kHz, 24 steps				
G <sub>v</sub>	nominal volume control		-24	-	0	dB
	minimum volume control		-23	-	-1	dB
	gain in mute position		-80	-85	-	dB
ΔG <sub>v</sub>	step width		0.5	1.0	1.5	dB
	gain tracking error		-	-	2	dB
<b>Bass control</b>						
G <sub>v</sub>	controllable bass	C <sub>B</sub> = 33 nF				
	maximum boost	f = 40 Hz	14	15	16	dB
	maximum attenuation	f = 40 Hz	11	12	13	dB
ΔG <sub>v</sub>	step width		1	1.5	2	dB
G <sub>v</sub>	controllable enhanced bass	Fig.1				
	maximum boost	f = 60 Hz	18	19	20	dB
	maximum attenuation	f = 60 Hz	14	15	16	dB
ΔG <sub>v</sub>	step width		1	2	3	dB
<b>Treble control</b>						
G <sub>v</sub>	controllable treble					
	maximum boost	f = 15 kHz	11	12	13	dB
	maximum attenuation	f = 15 kHz	11	12	13	dB
ΔG <sub>v</sub>	step width (resolution)		2.5	3	3.5	dB
<b>Effect controls</b>						
α <sub>spat1</sub>	anti-phase crosstalk by spatial effect		-	52	-	%
α <sub>spat2</sub>			-	30	-	%
φ	phase shift by pseudo-stereo		-	Fig.3	-	
<b>Loudspeaker channel outputs (pins 15 and 18)</b>						
V <sub>o</sub>	maximum output signal (RMS value; pins 15 and 18)	THD ≤ 0.5%; R <sub>L</sub> > 10 kΩ; C <sub>L</sub> < 1.5 nF	2	-	-	V
ΔV <sub>15, 18</sub>	maximum DC offset voltage	between adjoining step and any step to mute				
	for volume control	G <sub>v</sub> = 0 to +15 dB/mute	-	2	15	mV
		G <sub>v</sub> = -64 to 0 dB/mute	-	0.5	10	mV
	for bass control	G <sub>v</sub> = 0 to +15 dB/mute	-	2	15	mV
		G <sub>v</sub> = -12 to 0 dB/mute	-	0.5	10	mV
for treble control	G <sub>v</sub> = -12 to +12 dB/mute	-	0.5	10	mV	
R <sub>o</sub>	output resistance (pins 15 and 18)		-	-	100	Ω
R <sub>L</sub>	allowed output load resistor		10	-	-	kΩ
C <sub>L</sub>	allowed output load capacitor		-	-	1.5	nF

## Universal HiFi audio processor for TV

## TDA9860

SYMBOL	PARAMETER	CONDITIONS	MIN.	TYP.	MAX.	UNIT
$V_{N(W)}$	weighted noise voltage at output (quasi-peak level)	CCIR468-3				
	for +15 dB gain		–	102	–	$\mu\text{V}$
	for 0 dB gain		–	32	–	$\mu\text{V}$
	for –40 dB gain		–	27	–	$\mu\text{V}$
	for mute position	$G_V = -80 \text{ dB}$	–	20	–	$\mu\text{V}$
B	AF bandwidth	–1 dB	–	20 to 20000	–	Hz
THD	total harmonic distortion	$f = 20 \text{ to } 12500 \text{ Hz}$				
	for $V_i = 0.2 \text{ V}$ (RMS value)	$G_V = -30 \text{ to } +15 \text{ dB}$	–	0.1	0.3	%
	for $V_i = 1 \text{ V}$ (RMS value)	$G_V = -30 \text{ to } 0 \text{ dB}$	–	0.1	0.3	%
	for $V_i = 2 \text{ V}$ (RMS value)	$G_V = -30 \text{ to } -6 \text{ dB}$	–	0.1	0.3	%
$\alpha_{sp}$	stereo channel separation	$f = 10 \text{ kHz}; G_V = 0 \text{ dB};$ opposite input grounded by 1 k $\Omega$ resistor	–	75	–	dB
$\alpha_{bus}$	crosstalk of I <sup>2</sup> C-bus	$G_V = 0 \text{ dB};$ note 1	–	100	–	dB
RR <sub>100</sub>	ripple rejection with 100 Hz ripple on $V_P$	$G_V = 0 \text{ dB};$ $V_R < 200 \text{ mV RMS}$	–	55	–	dB
<b>HEADPHONE CHANNEL</b> (controlled via I <sup>2</sup> C-bus, Table 3)						
<b>Volume control headphone channel</b>		$f = 1 \text{ kHz}, 36 \text{ steps}$				
$G_V$	nominal volume control		–70	–	0	dB
	minimum volume control		–67	–	–1	dB
	gain in mute position		–80	–85	–	dB
$\Delta G_V$	step width (resolution)	$G_V = -36 \text{ to } 0 \text{ dB}$	1.5	2	2.5	dB
		$G_V = -70 \text{ to } -36 \text{ dB}$	1	2	3	dB
	gain set error	$G_V = -36 \text{ to } 0 \text{ dB}$	–	–	1	dB
		$G_V = -70 \text{ to } -36 \text{ dB}$	–	–	3	dB
$\Delta V_{13, 20}$	DC offset voltage	for adjoining step and step to mute $G_V = -70 \text{ to } 0 \text{ dB}$	–	0.5	10	mV
<b>Headphone channel output</b> (pins 13 and 20)						
$V_o$	maximum output signal (RMS value)	THD $\leq 0.5\%$ ; $R_L > 10 \text{ k}\Omega$ ; $C_L < 1.5 \text{ nF}$	2	–	–	V
$R_o$	output resistance		–	–	100	$\Omega$
$R_L$	allowed output load resistor		10	–	–	k $\Omega$
$C_L$	allowed output load capacitor		–	–	1.5	nF
$V_{N(W)}$	weighted noise voltage at output (quasi-peak level) CCIR468-3					
	for 0 dB gain		–	20	–	$\mu\text{V}$
	for –16 dB gain		–	15	–	$\mu\text{V}$
	for mute position	$G_V = -80 \text{ dB}$	–	12	–	$\mu\text{V}$



## Universal HiFi audio processor for TV

TDA9860

SYMBOL	PARAMETER	CONDITIONS	MIN.	TYP.	MAX.	UNIT
B	AF bandwidth	-1 dB	-	20 to 20000	-	Hz
THD	total harmonic distortion	f = 20 to 12500 Hz				
	for $V_i = 1$ V (RMS value)	$G_V = -40$ to 0 dB	-	0.08	0.25	%
$\alpha_{sp}$	stereo channel separation	f = 10 kHz; $G_V = 0$ dB; opposite input grounded by 1 k $\Omega$ resistor	-	75	-	dB
$\alpha_{bus}$	crosstalk of I <sup>2</sup> C-bus	$G_V = 0$ dB; note 1	-	100	-	dB
RR <sub>100</sub>	ripple rejection with 100 Hz ripple on $V_P$	$G_V = 0$ dB; $V_R < 200$ mV RMS	-	55	-	dB
<b>SCART output</b> (pins 7 and 26)						
$V_o$	maximum output signal (RMS value)	THD $\leq 0.5\%$ ; $R_L > 5$ k $\Omega$	2	-	-	V
$R_L$	admissible output load resistor		5	-	-	k $\Omega$
<b>Power on reset</b>						
$V_{PONR}$	increasing supply voltage					
	start of reset		-	-	2.5	V
	end of reset		5.2	6.0	6.8	V
$V_{PONR}$	decreasing supply voltage start of reset		4.4	5.2	6.0	V
<b>I<sup>2</sup>C-bus, SCL and SDA</b> (pins 16 and 17, observe I <sup>2</sup> C-bus specification)						
$V_{16, 17}$	input voltage HIGH-level		3	-	$V_P$	V
	input voltage LOW-level		0	-	1.5	V
$I_{16, 17}$	input current		-	-	$\pm 10$	$\mu$ A
$V_{ACK}$	output voltage at acknowledge (pin 17)	$I_{17} = -3$ mA	-	-	0.4	V
<b>Module address</b> (pin 25)						
$V_{IL}$	LOW level input voltage		0	-	1.5	V
$V_{IH}$	HIGH level input voltage		3	-	$V_P$	V
<b>Port outputs P1 and P2</b> (open-collector outputs pins 2 and 31)						
$V_{OL}$	LOW level output voltage	$I_{2, 31} = 1$ mA (sink)	-	-	0.3	V
$I_{2, 31}$	port output current	sink current	-	-	1	mA

**Note to the characteristics**

- $\alpha_{bus} = 20 \log V_{bus} / V_o$  ( $V_{bus}$  = spurious bus signal voltage on AF output pin).

## Universal HiFi audio processor for TV

TDA9860

**I<sup>2</sup>C-BUS FORMAT**

S	SLAVE ADDRESS	A	SUBADDRESS	A	DATA	P
---	---------------	---	------------	---	------	---

S	= start condition
SLAVE ADDRESS	= 1000 0000 ( $V_{25}$ = LOW) or 1000 0010 ( $V_{25}$ = HIGH)
A	= acknowledge, generated by the slave or by the master
SUBADDRESS	= subaddress byte, see Table 1
DATA	= data byte, see Table 1
P	= stop condition

This circuit only operates as a slave transmitter.

If more than 1 byte of DATA is transmitted, then auto-increment of the subaddress is performed.

**Byte organisation****Table 1** I<sup>2</sup>C-bus transmission.

FUNCTION	SUBADDRESS	HEX	DATA							
			D7	D6	D5	D4	D3	D2	D1	D0
<b>loudspeaker channel</b>										
volume control both	0000 0000	00	0	0	V05	V04	V03	V02	V01	V00
volume/balance left	0000 0001	01	0	0	0	VL4	VL3	VL2	VL1	VL0
volume/balance right	0000 0010	02	0	0	0	VR4	VR3	VR2	VR1	VR0
bass control byte	0000 0011	03	0	0	0	BA4	BA3	BA2	BA1	BA0
treble control byte	0000 0100	04	0	0	0	0	TR3	TR2	TR1	TR0
<b>headphone channel</b>										
volume control left	0000 0101	05	0	0	VHL5	VHL4	VHL3	VHL2	VHL1	VHL0
volume control right	0000 0110	06	0	0	VHR5	VHR4	VHR3	VHR2	VHR1	VHR0
<b>switching control byte</b>										
headphone output	0000 0111	07	0	MU0	0	0	I03	I02	I01	I00
SCART output	0000 1000	08	0	MU1	P1	P2	I13	I12	I11	I10
loudspeaker output	0000 1001	09	EF2	MU2	EF1	ST	I23	I22	I21	I20

## Universal HiFi audio processor for TV

TDA9860

**Table 2** Bits of data bytes.

FUNCTION OF THE BITS IN TABLE 1	DESCRIPTION
V00 to V05	volume control common for loudspeaker channel
VL0 to VL4	volume control LEFT for loudspeaker channel
VR0 to VR4	volume control RIGHT for loudspeaker channel
BA0 to BA4	bass control for LEFT and RIGHT loudspeaker channel
TR0 to TR3	treble control for LEFT and RIGHT loudspeaker channel
VHL0 to VHL5	volume control LEFT for headphone channel
VHR0 to VHR5	volume control RIGHT for headphone channel
I00 to I03	input selection for headphone channel
I10 to I13	input selection for SCART channel
I20 to I23	input selection for loudspeaker channel
MU0, MU1 and MU2	mute control bits: 0 = non-muted; 1 = muted
EF1, EF2 and ST	special mode control bits
P1 and P2	control bits for port P1 (pin 2) and P2 (pin 31): output levels: 0 = LOW; 1 = HIGH

**Table 3** Output and input selection by subaddress bytes 07, 08 and 09.

OUTPUT AND INPUT CONTROL BYTES, MUTE INCLUDED (EFFECTS TABLE 4)												
SELECT OUTPUT PINS		INPUT GROUP	INPUT SIGNAL	ADDR	DATA BYTE TO SUBADDRESS							
<b>Loudspeaker channels</b>												
output pin 18	output pin 15			09	EF2	MU2	EF1	ST	I23	I22	I21	I20
<b>SCART channels</b>												
output pin 26	output pin 7			08	0	MU1	P1	P2	I13	I12	I11	I10
<b>headphone channels</b>												
output pin 20	output pin 13			07	0	MU0	0	0	I03	I02	I01	I00
SELECT INPUT SIGNAL PINS				HEX	BITS OF DATA BYTE							
28	28	AUX LEFT	$V_{i1}$	XB	X	0	X	X	1	0	1	1
30	30	AUX RIGHT	$V_{i2}$	X9	X	0	X	X	1	0	0	1
28	30	AUX STEREO	$V_{i1}$ and $V_{i2}$	X7	X	0	X	X	0	1	1	1
1	1	SCART LEFT	$V_{i3}$	XA	X	0	X	X	1	0	1	0
32	32	SCART RIGHT	$V_{i4}$	X5	X	0	X	X	0	1	0	1
1	32	SCART STEREO	$V_{i3}$ and $V_{i4}$	X6	X	0	X	X	0	1	1	0
3	3	MAIN LEFT	$V_{i5}$	XC	X	0	X	X	1	1	0	0
5	5	MAIN RIGHT	$V_{i6}$	XD	X	0	X	X	1	1	0	1
3	5	MAIN STEREO	$V_{i5}$ and $V_{i6}$	X8	X	0	X	X	1	0	0	0

**Note**

1. X = don't care

## Universal HiFi audio processor for TV

TDA9860

**Table 4** Effect controls.

SETTING SPECIAL MODES	HEX	DATA BYTE TO SUBADDRESS 09							
		EF2	MU2	EF1	ST	I23	I22	I21	I20
stereo with spatial (52%)	BX	1	0	1	1	X	X	X	X
stereo with spatial (30%)	3X	0	0	1	1	X	X	X	X
stereo without spatial	1X	0	0	0	1	X	X	X	X
forced mono with pseudo stereo	2X	0	0	1	0	X	X	X	X
forced mono without pseudo stereo	0X	0	0	0	0	X	X	X	X

**Table 5** Volume 2 / balance control LEFT.

G <sub>v</sub> (dB)	HEX	DATA				
		VL4	VL3	VL2	VL1	VL0
0	1F	1	1	1	1	1
-1	1E	1	1	1	1	0
-2	1D	1	1	1	0	1
-3	1C	1	1	1	0	0
-4	1B	1	1	0	1	1
-5	1A	1	1	0	1	0
-6	19	1	1	0	0	1
-7	18	1	1	0	0	0
-8	17	1	0	1	1	1
-9	16	1	0	1	1	0
-10	15	1	0	1	0	1
-11	14	1	0	1	0	0
-12	13	1	0	0	1	1
-13	12	1	0	0	1	0
-14	11	1	0	0	0	1
-15	10	1	0	0	0	0
-16	0F	0	1	1	1	1
-17	0E	0	1	1	1	0
-18	0D	0	1	1	0	1
-19	0C	0	1	1	0	0
-20	0B	0	1	0	1	1
-21	0A	0	1	0	1	0
-22	09	0	1	0	0	1
-23	08	0	1	0	0	0
mute left	07	0	0	1	1	1

**Table 6** Volume 2 / balance control RIGHT.

G <sub>v</sub> (dB)	HEX	DATA				
		VR4	VR3	VR2	VR1	VR0
0	1F	1	1	1	1	1
-1	1E	1	1	1	1	0
-2	1D	1	1	1	0	1
-3	1C	1	1	1	0	0
-4	1B	1	1	0	1	1
-5	1A	1	1	0	1	0
-6	19	1	1	0	0	1
-7	18	1	1	0	0	0
-8	17	1	0	1	1	1
-9	16	1	0	1	1	0
-10	15	1	0	1	0	1
-11	14	1	0	1	0	0
-12	13	1	0	0	1	1
-13	12	1	0	0	1	0
-14	11	1	0	0	0	1
-15	10	1	0	0	0	0
-16	0F	0	1	1	1	1
-17	0E	0	1	1	1	0
-18	0D	0	1	1	0	1
-19	0C	0	1	1	0	0
-20	0B	0	1	0	1	1
-21	0A	0	1	0	1	0
-22	09	0	1	0	0	1
-23	08	0	1	0	0	0
mute right	07	0	0	1	1	1

## Universal HiFi audio processor for TV

## TDA9860

**Table 7** Volume 1 to control both channels.

$G_v$ (dB)	DATA						
	HEX	V05	V04	V03	V02	V01	V00
+15	3F	1	1	1	1	1	1
+14	3E	1	1	1	1	1	0
+13	3D	1	1	1	1	0	1
+12	3C	1	1	1	1	0	0
+11	3B	1	1	1	0	1	1
+10	3A	1	1	1	0	1	0
+9	39	1	1	1	0	0	1
+8	38	1	1	1	0	0	0
+7	37	1	1	0	1	1	1
+6	36	1	1	0	1	1	0
+5	35	1	1	0	1	0	1
+4	34	1	1	0	1	0	0
+3	33	1	1	0	0	1	1
+2	32	1	1	0	0	1	0
+1	31	1	1	0	0	0	1
0	30	1	1	0	0	0	0
-1	2F	1	0	1	1	1	1
-2	2E	1	0	1	1	1	0
-3	2D	1	0	1	1	0	1
-4	2C	1	0	1	1	0	0
-5	2B	1	0	1	0	1	1
-6	2A	1	0	1	0	1	0
-7	29	1	0	1	0	0	1
-8	28	1	0	1	0	0	0
-9	27	1	0	0	1	1	1
-10	26	1	0	0	1	1	0
-11	25	1	0	0	1	0	1
-12	24	1	0	0	1	0	0
-13	23	1	0	0	0	1	1
-14	22	1	0	0	0	1	0
-15	21	1	0	0	0	0	1
-16	20	1	0	0	0	0	0

$G_v$ (dB)	DATA						
	HEX	V05	V04	V03	V02	V01	V00
-17	1F	0	1	1	1	1	1
-18	1E	0	1	1	1	1	0
-19	1D	0	1	1	1	0	1
-20	1C	0	1	1	1	0	0
-21	1B	0	1	1	0	1	1
-22	1A	0	1	1	0	1	0
-23	19	0	1	1	0	0	1
-24	18	0	1	1	0	0	0
-25	17	0	1	0	1	1	1
-26	16	0	1	0	1	1	0
-27	15	0	1	0	1	0	1
-28	14	0	1	0	1	0	0
-29	13	0	1	0	0	1	1
-30	12	0	1	0	0	1	0
-31	11	0	1	0	0	0	1
-32	10	0	1	0	0	0	0
-33	0F	0	0	1	1	1	1
-34	0E	0	0	1	1	1	0
-35	0D	0	0	1	1	0	1
-36	0C	0	0	1	1	0	0
-37	0B	0	0	1	0	1	1
-38	0A	0	0	1	0	1	0
-39	09	0	0	1	0	0	1
-40	08	0	0	1	0	0	0

## Universal HiFi audio processor for TV

## TDA9860

**Table 8** Bass control LEFT and RIGHT.

$G_v$ (dB)	DATA					
	HEX	BA4	BA3	BA2	BA1	BA0
+15	19	1	1	0	0	1
+13.5	18	1	1	0	0	0
+12	17	1	0	1	1	1
+10.5	16	1	0	1	1	0
+9	15	1	0	1	0	1
+7.5	14	1	0	1	0	0
+6	13	1	0	0	1	1
+4.5	12	1	0	0	1	0
+3	11	1	0	0	0	1
+1.5	10	1	0	0	0	0
0	0F	0	1	1	1	1
0	0E	0	1	1	1	0
-1.5	0D	0	1	1	0	1
-3	0C	0	1	1	0	0
-4.5	0B	0	1	0	1	1
-6	0A	0	1	0	1	0
-7.5	09	0	1	0	0	1
-9	08	0	1	0	0	0
-10.5	07	0	0	1	1	1
-12	06	0	0	1	1	0

**Table 9** Treble control LEFT and RIGHT.

$G_v$ (dB)	DATA					
	HEX	0	TR3	TR2	TR1	TR0
+12	0A	0	1	0	1	0
+9	09	0	1	0	0	1
+6	08	0	1	0	0	0
+3	07	0	0	1	1	1
0	06	0	0	1	1	0
-3	05	0	0	1	0	1
-6	04	0	0	1	0	0
-9	03	0	0	0	1	1
-12	02	0	0	0	1	0

## Universal HiFi audio processor for TV

## TDA9860

Table 10 Volume control of headphone LEFT.

$G_v$ (dB)	HEX	DATA					
		VHL 5	VHL 4	VHL 3	VHL 2	VHL 1	VHL 0
0	3F	1	1	1	1	1	1
-2	3E	1	1	1	1	1	0
-4	3D	1	1	1	1	0	1
-6	3C	1	1	1	1	0	0
-8	3B	1	1	1	0	1	1
-10	3A	1	1	1	0	1	0
-12	39	1	1	1	0	0	1
-14	38	1	1	1	0	0	0
-16	37	1	1	0	1	1	1
-18	36	1	1	0	1	1	0
-20	35	1	1	0	1	0	1
-22	34	1	1	0	1	0	0
-24	33	1	1	0	0	1	1
-26	32	1	1	0	0	1	0
-28	31	1	1	0	0	0	1
-30	30	1	1	0	0	0	0
-32	2F	1	0	1	1	1	1
-34	2E	1	0	1	1	1	0
-36	2D	1	0	1	1	0	1
-38	2C	1	0	1	1	0	0
-40	2B	1	0	1	0	1	1
-42	2A	1	0	1	0	1	0
-44	29	1	0	1	0	0	1
-46	28	1	0	1	0	0	0
-48	27	1	0	0	1	1	1
-50	26	1	0	0	1	1	0
-52	25	1	0	0	1	0	1
-54	24	1	0	0	1	0	0
-56	23	1	0	0	0	1	1
-58	22	1	0	0	0	1	0
-60	21	1	0	0	0	0	1
-62	20	1	0	0	0	0	0
-64	1F	0	1	1	1	1	1
-66	1E	0	1	1	1	1	0
-68	1D	0	1	1	1	0	1
-70	1C	0	1	1	1	0	0
mute left	1B	0	1	1	0	1	1

Table 11 Volume control of headphone RIGHT.

$G_v$ (dB)	HEX	DATA					
		VHR 5	VHR 4	VHR 3	VHR 2	VHR 1	VHR 0
0	3F	1	1	1	1	1	1
-2	3E	1	1	1	1	1	0
-4	3D	1	1	1	1	0	1
-6	3C	1	1	1	1	0	0
-8	3B	1	1	1	0	1	1
-10	3A	1	1	1	0	1	0
-12	39	1	1	1	0	0	1
-14	38	1	1	1	0	0	0
-16	37	1	1	0	1	1	1
-18	36	1	1	0	1	1	0
-20	35	1	1	0	1	0	1
-22	34	1	1	0	1	0	0
-24	33	1	1	0	0	1	1
-26	32	1	1	0	0	1	0
-28	31	1	1	0	0	0	1
-30	30	1	1	0	0	0	0
-32	2F	1	0	1	1	1	1
-34	2E	1	0	1	1	1	0
-36	2D	1	0	1	1	0	1
-38	2C	1	0	1	1	0	0
-40	2B	1	0	1	0	1	1
-42	2A	1	0	1	0	1	0
-44	29	1	0	1	0	0	1
-46	28	1	0	1	0	0	0
-48	27	1	0	0	1	1	1
-50	26	1	0	0	1	1	0
-52	25	1	0	0	1	0	1
-54	24	1	0	0	1	0	0
-56	23	1	0	0	0	1	1
-58	22	1	0	0	0	1	0
-60	21	1	0	0	0	0	1
-62	20	1	0	0	0	0	0
-64	1F	0	1	1	1	1	1
-66	1E	0	1	1	1	1	0
-68	1D	0	1	1	1	0	1
-70	1C	0	1	1	1	0	0
mute right	1B	0	1	1	0	1	1

Universal HiFi audio processor for TV

TDA9860

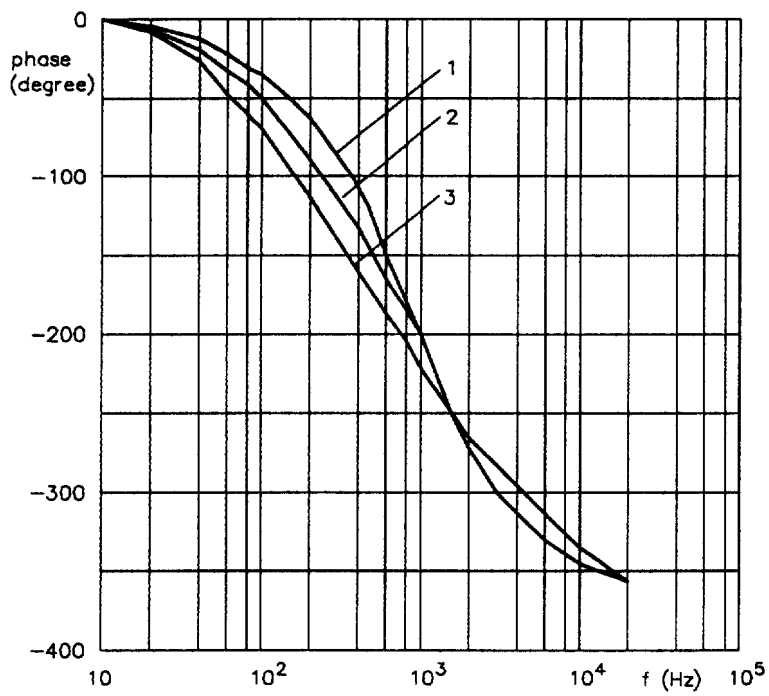

Fig.3 Pseudo (phase) as a function of frequency.

CURVE	CAPACITANCE AT PIN 29 (nF)	CAPACITANCE AT PIN 27 (nF)	EFFECT
1	15	15	normal
2	47	5.6	intensified
3	68	5.6	more intensified



Universal HiFi audio processor for TV

TDA9860

PACKAGE OUTLINE

SDIP32: plastic shrink dual in-line package; 32 leads (400 mil)

SOT232-1

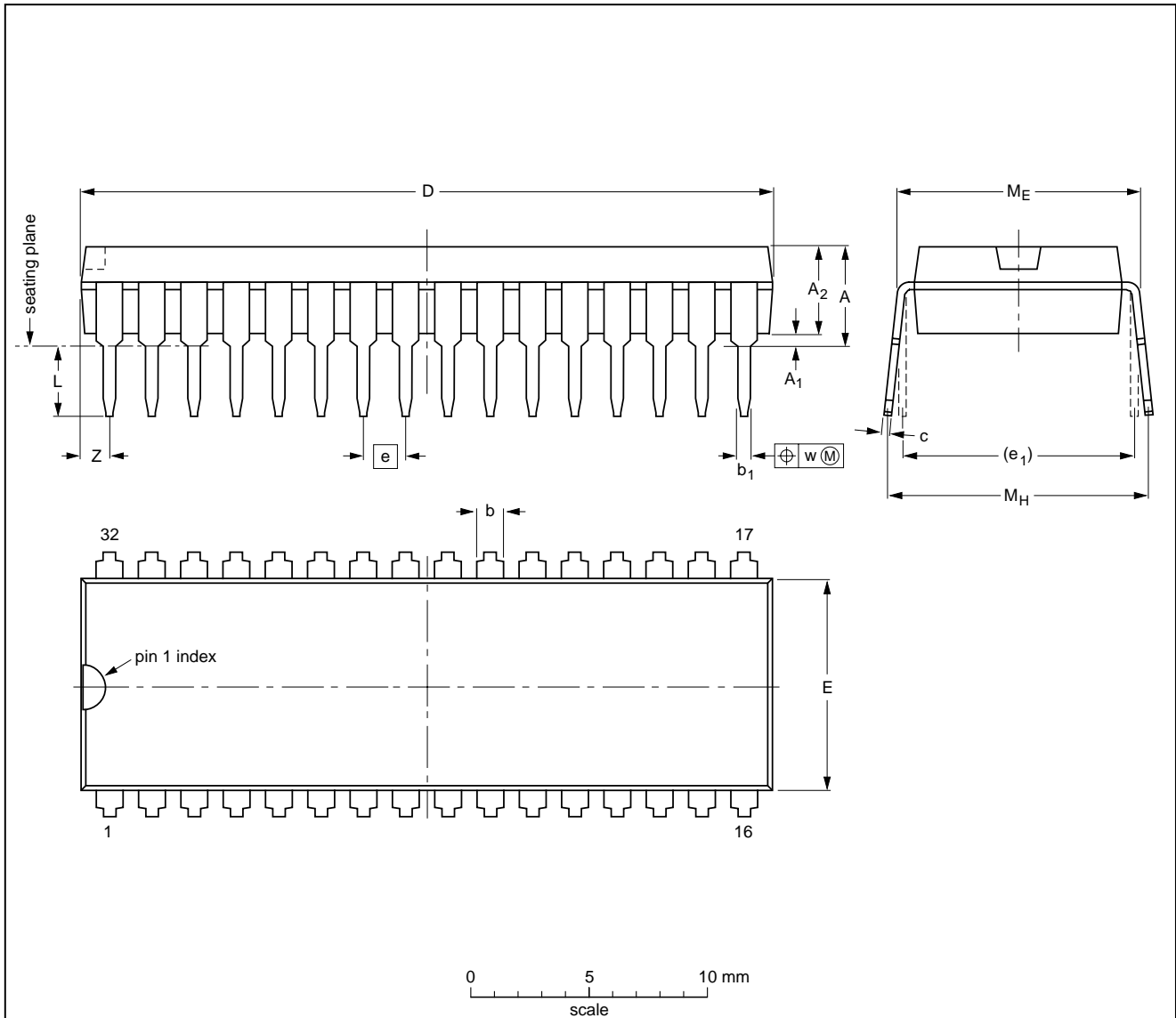

DIMENSIONS (mm are the original dimensions)

UNIT	A max.	A <sub>1</sub> min.	A <sub>2</sub> max.	b	b <sub>1</sub>	c	D <sup>(1)</sup>	E <sup>(1)</sup>	e	e <sub>1</sub>	L	M <sub>E</sub>	M <sub>H</sub>	w	Z <sup>(1)</sup> max.
mm	4.7	0.51	3.8	1.3 0.8	0.53 0.40	0.32 0.23	29.4 28.5	9.1 8.7	1.778	10.16	3.2 2.8	10.7 10.2	12.2 10.5	0.18	1.6

Note

1. Plastic or metal protrusions of 0.25 mm maximum per side are not included.

OUTLINE VERSION	REFERENCES				EUROPEAN PROJECTION	ISSUE DATE
	IEC	JEDEC	EIAJ			
SOT232-1						92-11-17 95-02-04

# Universal HiFi audio processor for TV

# TDA9860

## SOLDERING

### Introduction

There is no soldering method that is ideal for all IC packages. Wave soldering is often preferred when through-hole and surface mounted components are mixed on one printed-circuit board. However, wave soldering is not always suitable for surface mounted ICs, or for printed-circuits with high population densities. In these situations reflow soldering is often used.

This text gives a very brief insight to a complex technology. A more in-depth account of soldering ICs can be found in our "IC Package Databook" (order code 9398 652 90011).

### Soldering by dipping or by wave

The maximum permissible temperature of the solder is 260 °C; solder at this temperature must not be in contact

with the joint for more than 5 seconds. The total contact time of successive solder waves must not exceed 5 seconds.

The device may be mounted up to the seating plane, but the temperature of the plastic body must not exceed the specified maximum storage temperature ( $T_{stg\ max}$ ). If the printed-circuit board has been pre-heated, forced cooling may be necessary immediately after soldering to keep the temperature within the permissible limit.

### Repairing soldered joints

Apply a low voltage soldering iron (less than 24 V) to the lead(s) of the package, below the seating plane or not more than 2 mm above it. If the temperature of the soldering iron bit is less than 300 °C it may remain in contact for up to 10 seconds. If the bit temperature is between 300 and 400 °C, contact may be up to 5 seconds.

## DEFINITIONS

<b>Data sheet status</b>	
Objective specification	This data sheet contains target or goal specifications for product development.
Preliminary specification	This data sheet contains preliminary data; supplementary data may be published later.
Product specification	This data sheet contains final product specifications.
<b>Limiting values</b>	
Limiting values given are in accordance with the Absolute Maximum Rating System (IEC 134). Stress above one or more of the limiting values may cause permanent damage to the device. These are stress ratings only and operation of the device at these or at any other conditions above those given in the Characteristics sections of the specification is not implied. Exposure to limiting values for extended periods may affect device reliability.	
<b>Application information</b>	
Where application information is given, it is advisory and does not form part of the specification.	

## LIFE SUPPORT APPLICATIONS

These products are not designed for use in life support appliances, devices, or systems where malfunction of these products can reasonably be expected to result in personal injury. Philips customers using or selling these products for use in such applications do so at their own risk and agree to fully indemnify Philips for any damages resulting from such improper use or sale.

## PURCHASE OF PHILIPS I<sup>2</sup>C COMPONENTS



Purchase of Philips I<sup>2</sup>C components conveys a license under the Philips' I<sup>2</sup>C patent to use the components in the I<sup>2</sup>C system provided the system conforms to the I<sup>2</sup>C specification defined by Philips. This specification can be ordered using the code 9398 393 40011.